

Designed for use in plenum applications.

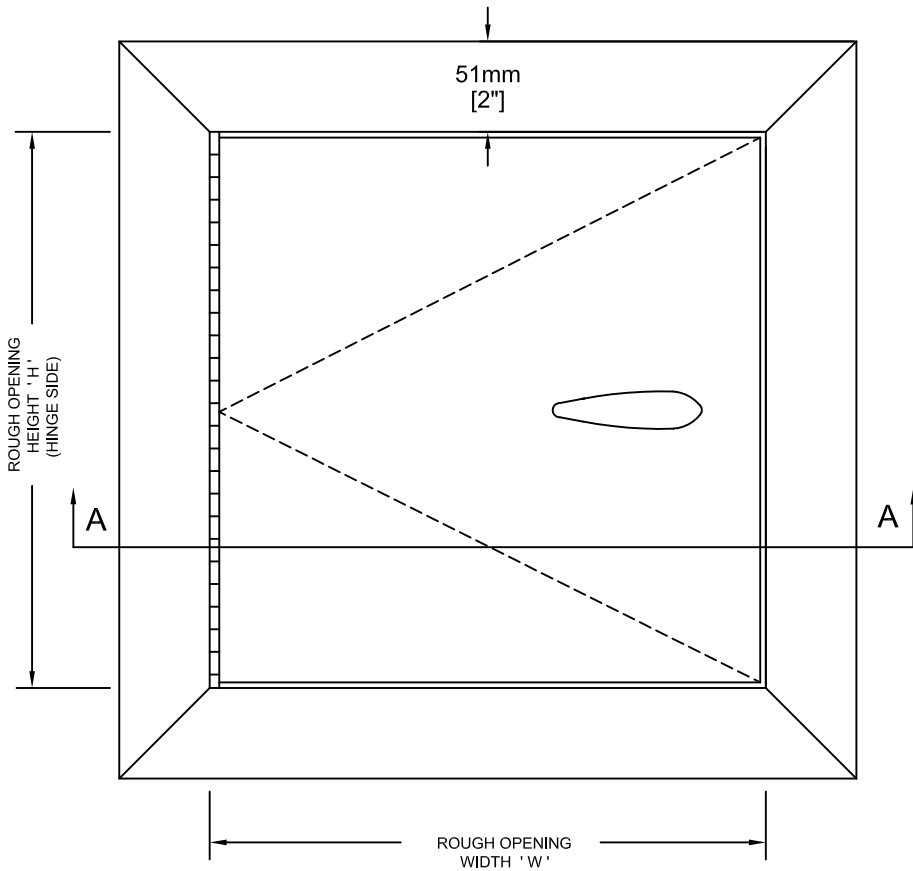

FRONT ELEVATION

STANDARD CONSTRUCTION:

- MATERIAL** - SATIN FINISH GALVANIZED (GALVANNEALED) STEEL.
- PANEL** - 1.31mm [18 ga]
- LINER** - 1.31mm [18 ga]
- FRAME** - 1.31mm [18 ga]
- FLANGE** - 51mm [2\"] EXTERIOR FLANGE.
- HINGE** - CONTINUOUS STAINLESS STEEL PIANO HINGE. [OPENS TO 180°]
- LATCH** - COMPRESSION HANDLE OPERABLE FROM BOTH SIDES. NOT AVAILABLE IN STAINLESS STEEL.
- GASKET** - FRAME GASKETED ON ALL FOUR SIDES.
- INSULATION**- 51mm [2\"] THICK FIBERGLASS.
- FINISH** - MILL FINISH GALVANIZED STEEL c/w A RICH ZINC PAINT ON ALL WELDS.

* Specifications subject to change without notice.

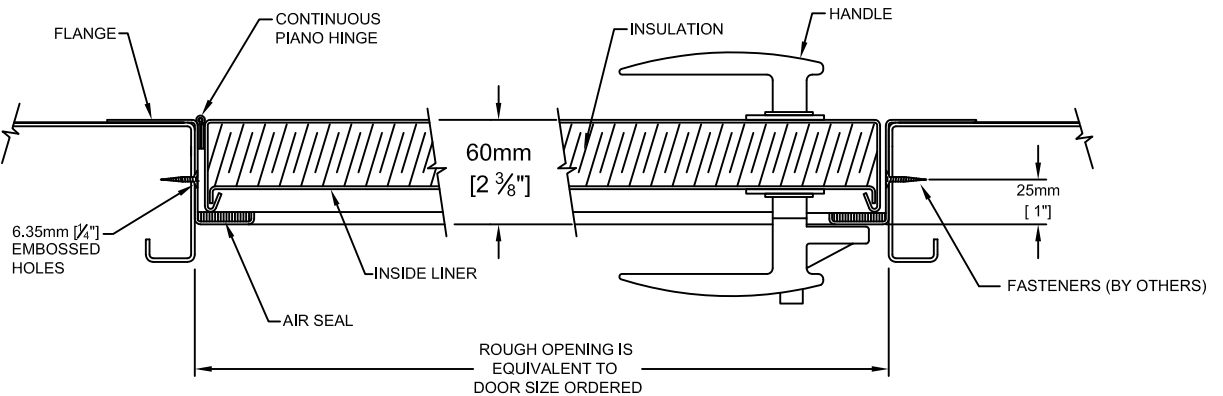

SECTION A-A

PROJECT: _____

CONTRACTOR: _____

ARCH. OR ENG.: _____

DATE: _____

These drawings are the property of Maxam Metal Products Ltd. and incorporates information which is proprietary. Publication and/or public distribution in whole or in part is expressly prohibited without the prior written consent of Maxam Metal Products Ltd. The information herein remains the property of Maxam Metal Products Ltd. All rights reserved.

DWN BY KB	DATE Feb. / 2014	DWG. NO. Sheet 1 of 2	REV. 
--------------	---------------------	--------------------------	---

