

## VAN-MET® MODEL NDI - Drywall Insert

manufactured to the **Van-Met®** design standard

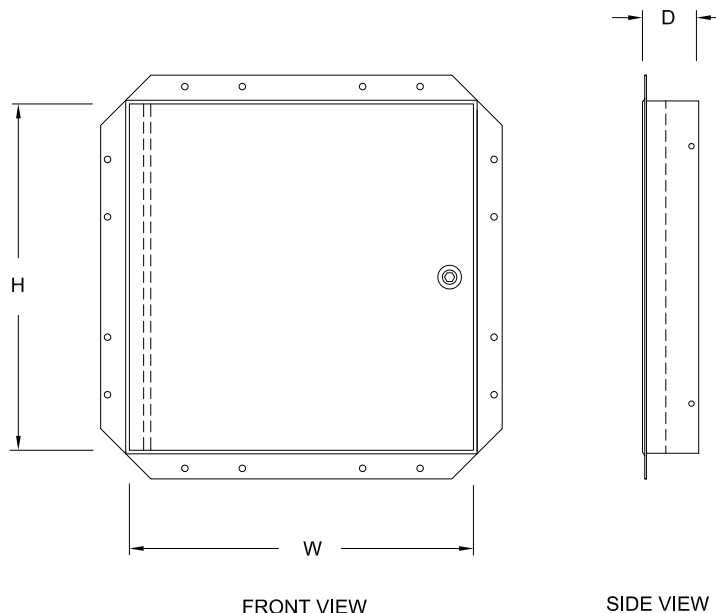

- Ideal when a concealed appearance is desired.
- Door panel is recessed to receive drywall.
- Designed with a galvanized steel drywall bead taping flange, specifically for use with drywall.
- Install after the drywall has been applied.
- Drywall compound is applied over the beading at the same time the drywall joints are finished.
- Exterior appearance is compatible with the non-rated and fire-rated Van-Met access door line.

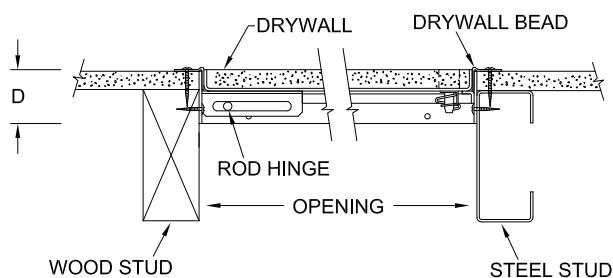

**Concealed Rod Hinge**

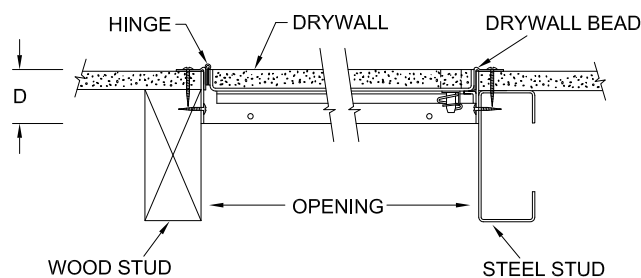

**Optional: Piano Hinge**

### Materials

Satin finish galvanized steel  
 Frame – 1.61mm (16ga)  
 Panel – 1.61mm (16ga)

### Finish

The paint finish is a rust inhibitive off-white prime coat.

### Hinges

#### Rod Hinge

The concealed rod hinge is designed to secure the door panel. The hinge is placed on the long side of the door ("H" dimension) unless otherwise requested.

### Optional: Piano Hinge

The continuous piano hinge allows the door panel to open 175° for easy access. The hinge is placed on the long side of the door ("H" dimension) unless otherwise requested.

**Note:** Piano hinge standard on doors greater than 610mm x 914mm (24" x 36").

### Latch

#### Standard

3/16" allen key cam

#### Optional Lock

Cylinder key lock

### Flange

Galvanized steel drywall bead taping flange

### Frame Depth

"D" = 48mm (1 7/8")

### Panel Depth

Standard - 16mm (5/8")

Optional - 25mm (1/2")

### Ordering

Please order by rough opening size and specify panel depth. These doors are non-returnable.

### Installation

The outer galvanized steel taping flange and inner frame are manufactured with pre-punched mounting holes. For a square fit, keep the door panel closed while installing.