

VAN-MET® NON-RATED ACCESS DOOR
MODEL NPL – PLENUM ACCESS

SPECIFICATIONS

- MATERIAL:** GALVANIZED STEEL
PANEL: 1.31 mm (16ga)
LINER: 1.31 mm (16ga)
FRAME: 1.31 mm (16ga)
FLANGE: 51mm (2") EXTERIOR FLANGE
HINGE: CONTINUOUS STAINLESS STEEL PIANO HINGE (OPENS TO 180°)
LATCH: COMPRESSION HANDLE OPERABLE FROM BOTH SIDES, NOT AVAILABLE IN STAINLESS STEEL.
GASKET: FRAME GASKETED ON ALL FOUR SIDES
INSULATION: 51mm (2") THICK FIBREGLOSS
FINISH: MILL FINISH GALVANIZED COMPLETE WITH A RICH ZINC PAINT ON ALL WELDS

OPTIONS (CHECK OFF REQUIRED OPTIONS)

- ALLOY 304 2B FINISH STAINLESS STEEL
- ALLOY 316 2B FINISH STAINLESS STEEL
- MOUNTING HOLES AVAILABLE ON EXTERIOR FLANGE

NOTE: HANDLE ONLY AVAILABLE IN A ZINC ALLOY.

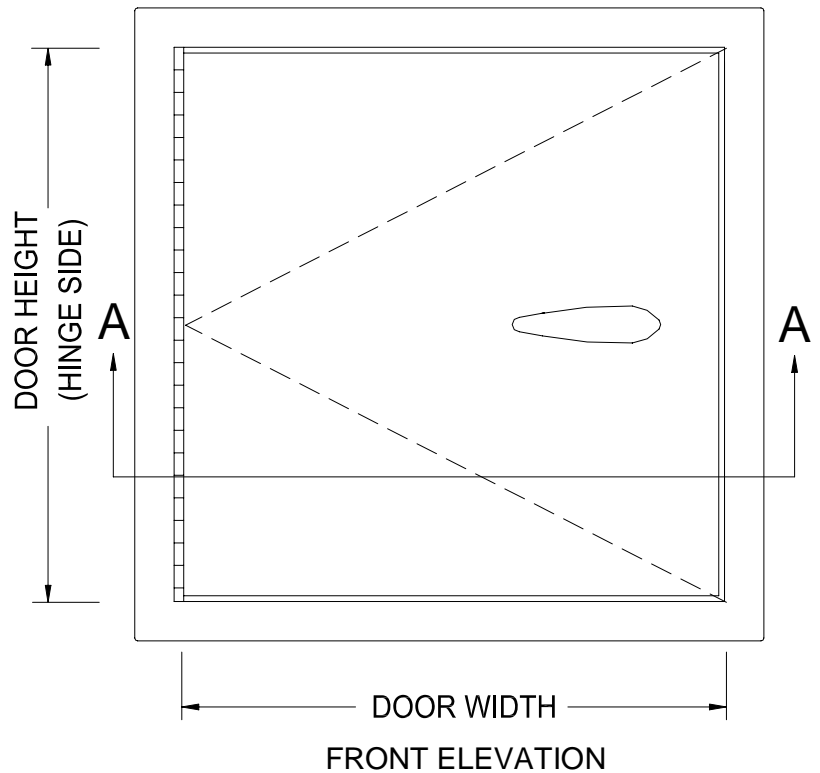

Model NPL met the performance criteria as per CSA A440-00 (windows) for an Air Tightness rating of A-3 at infiltration pressures of 75 Pa and 300 Pa, and at exfiltration pressures of 75 Pa and 300 Pa.
 Tested by Intertek / Warnock Hersey.

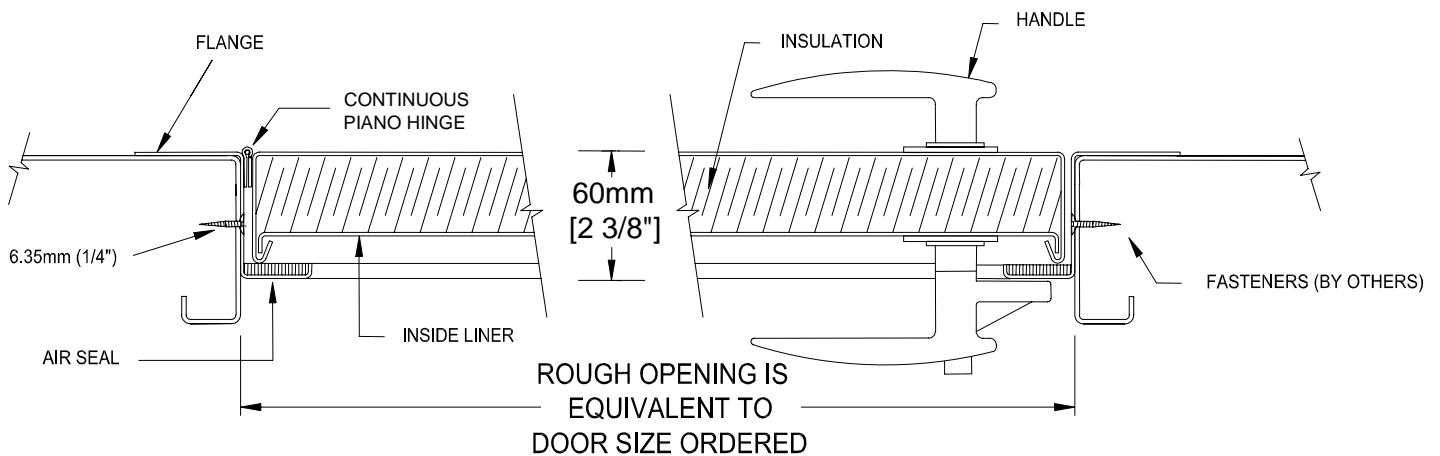

SECTION A-A



Maxam Metal Products Ltd.
 Unit 5- 7978 North Fraser Way
 Burnaby, BC, Canada V5J 0C7

Tel: 604-433-4243
 Fax: 604-433-4148

Website: www.maxammetal.com
 Email: info@maxammetal.com

| | | | |
|------------------|---------------------|-----------|-------------------|
| PROJECT: | | | |
| CONTRACTOR: | | | |
| ARCHITECT: | | | |
| DRAWN BY: KJK | DATE: 01/01/2003 | QUANTITY: | TITLE: NPL.DWG |

* Specifications subject to change without notice.