

# Model MT - Non-Rated Aluminum Floor Door, Single Leaf

## Standard Size Chart

Quantity	Model	Opening Size Measurements W x H		Rough-in Size Measurements W x H		Wt. in kgs. / Unit	Wt. in lbs. / Unit
		Metric (mm)	Inches	Metric (mm)	Inches		
	MT-0	610 x 914	24 x 36	787 x 1092	31 x 43	34	75
	MT-1	610 x 610	24 x 24	787 x 787	31 x 31	30	66
	MT-2	762 x 762	30 x 30	940 x 940	37 x 37	39	85
	MT-3	914 x 762	36 x 30	1092 x 940	43 x 37	43	95
	MT-4	914 x 914	36 x 36	1092 x 1092	43 x 43	48	106
	MT-5	1067 x 1067	42 x 42	1245 x 1245	49 x 49	62	136

Hinge Side

Hinge Side

## Non-Standard Size - (inches)

Quantity	Opening Size		Rough-in Size		Options
	W	H	W	H	

Hinge Side

Hinge Side

- ORDER BY OPENING SIZE.
- THE SECOND DIMENSION "H" IS THE HINGE SIDE.
- THESE DIMENSIONS ARE NOT A CLEAR OPENING SIZE.
- ROUGH-IN SIZE IS 178mm [7"] LARGER THAN OPENING SIZE ORDERED, IN BOTH DIMENSIONS.
- FOR MANUFACTURING ALLOW MINIMUM 4 WEEKS.

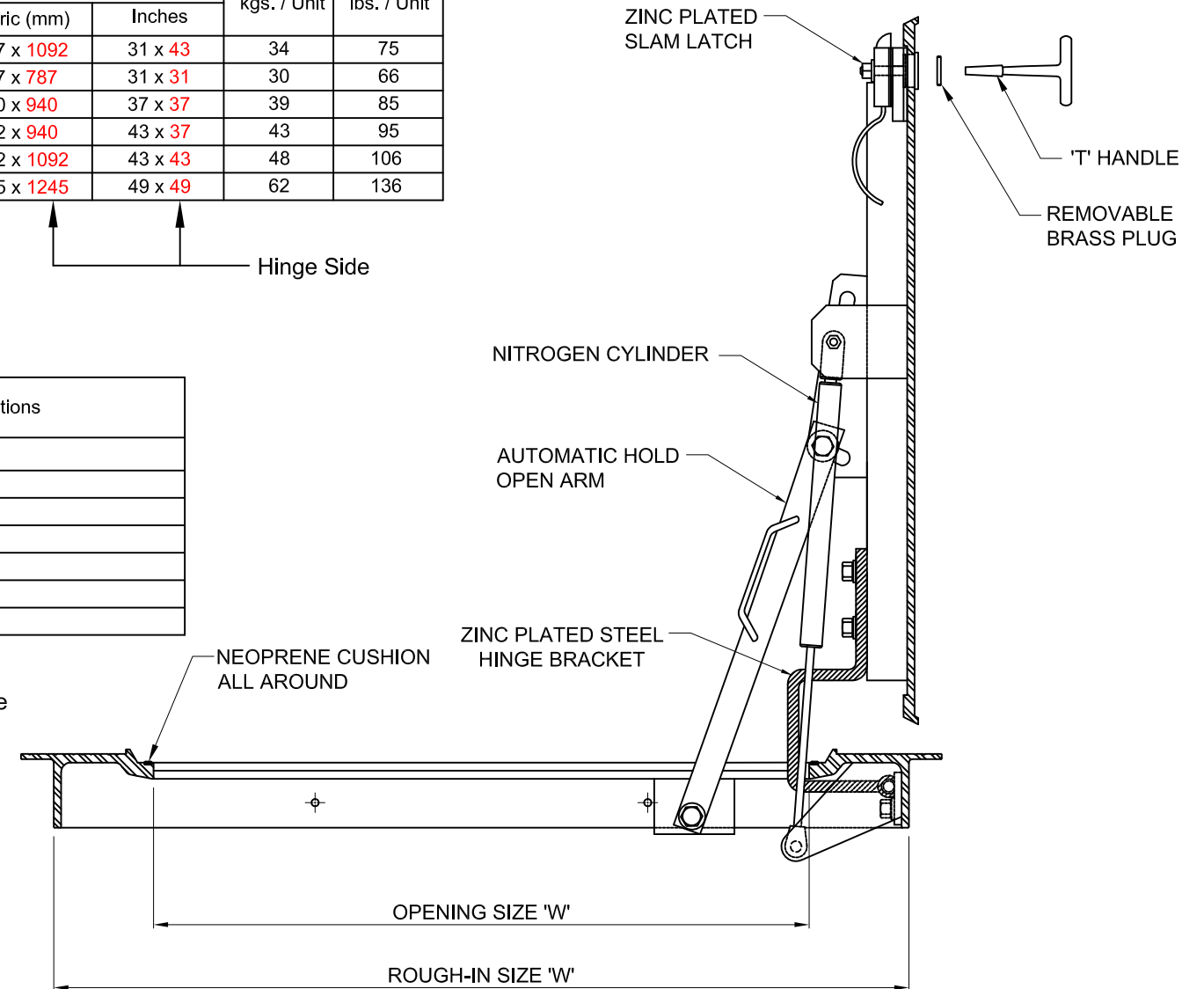
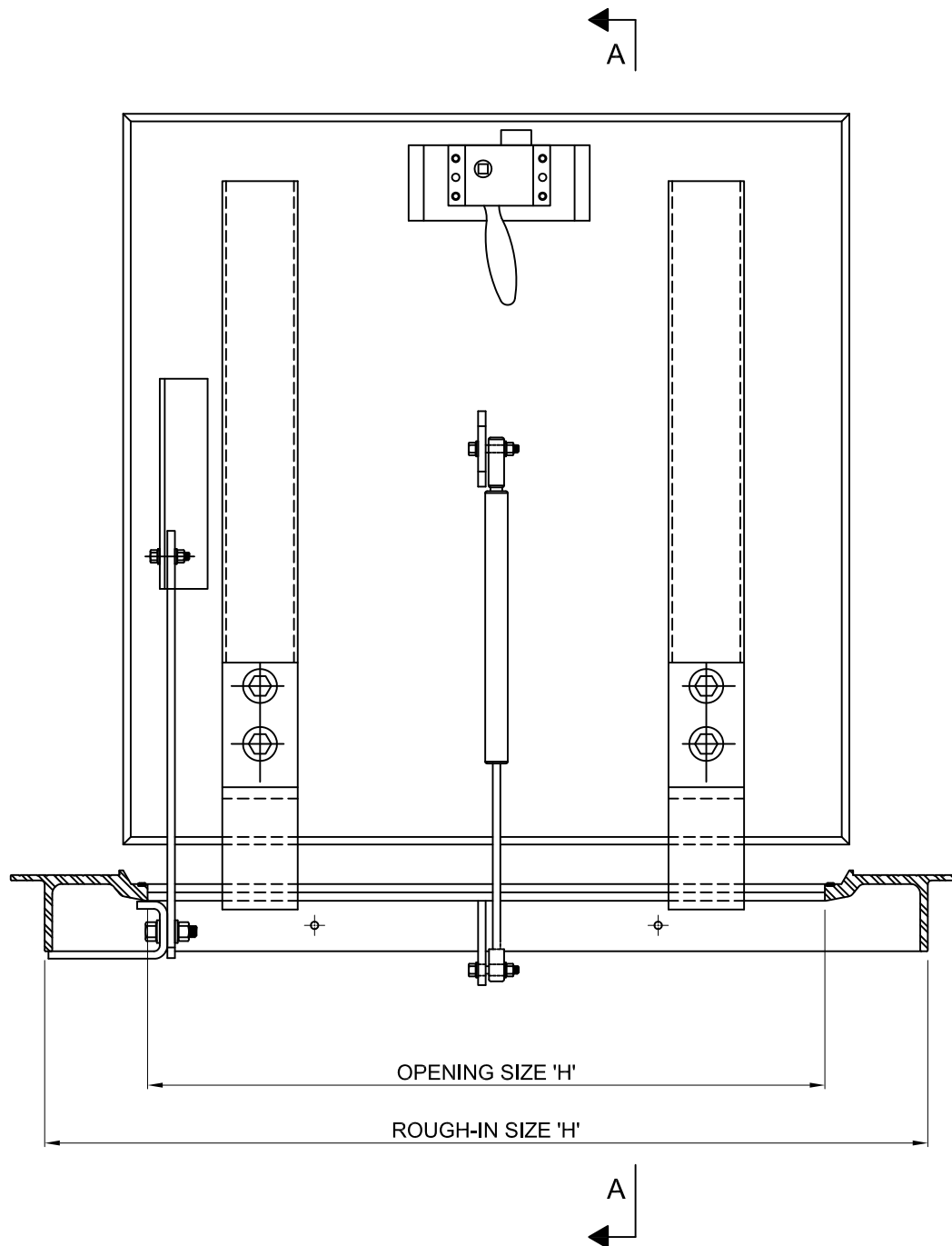

## SECTION 'A-A'

**NOTE:**  
- READ THIS DRAWING IN CONJUNCTION WITH SHEET 2 OF 2.

### STANDARD CONSTRUCTION:

- DOOR PANEL** - 6.35mm [ $\frac{1}{4}$ "] ALUMINUM PLATE RECESSED TO ACCEPT 3mm [ $\frac{3}{8}$ "] OR 5mm [ $\frac{3}{16}$ "] FLOOR COVERING.
- LIVE LOAD** - 700 kg/sq. meter [150lbs/sf].
- FRAMES** - 8mm [ $\frac{5}{16}$ "] NOMINAL, 6061-T6 EXTRUDED ALUMINUM WITH BUILT-IN NEOPRENE CUSHION RECESSED IN FRAME. FRAME DEPTH = 63.5mm [2½"].
- HINGE** - ZINC PLATED STEEL HINGE BRACKETS c/w STAINLESS STEEL BEARING AND PIN.

- LATCH** - ZINC PLATED, NON-LOCKING LATCH OPERABLE FROM TOP AND BOTTOM, c/w " T " HANDLE AND REMOVABLE PLUG.
- PANEL OPERATOR** - 316 STAINLESS STEEL NITROGEN CYLINDERS DESIGNED TO COUNTER BALANCE THE DOOR PANEL.
- HOLD OPEN ARM** - AUTOMATICALLY LOCKING, c/w RELEASE HANDLE. THE ARM IS PAINTED SAFETY RED.
- FINISHES** - ALUMINUM FRAMES - MILL FINISH. ALUMINUM DOOR PANEL - MILL FINISH.

△ LATEST REVISION 08/23/21



#5 7978 North Fraser Way  
Burnaby B.C. V5J 0C7  
Ph. 604-433-4243  
Fax. 604-433-4148

PROJECT :	
CONTRACTOR :	
ARCH. OR ENG. :	
PURCHASE ORDER :	
APPROVED BY :	
DATE :	
	SHEET 1 OF 2

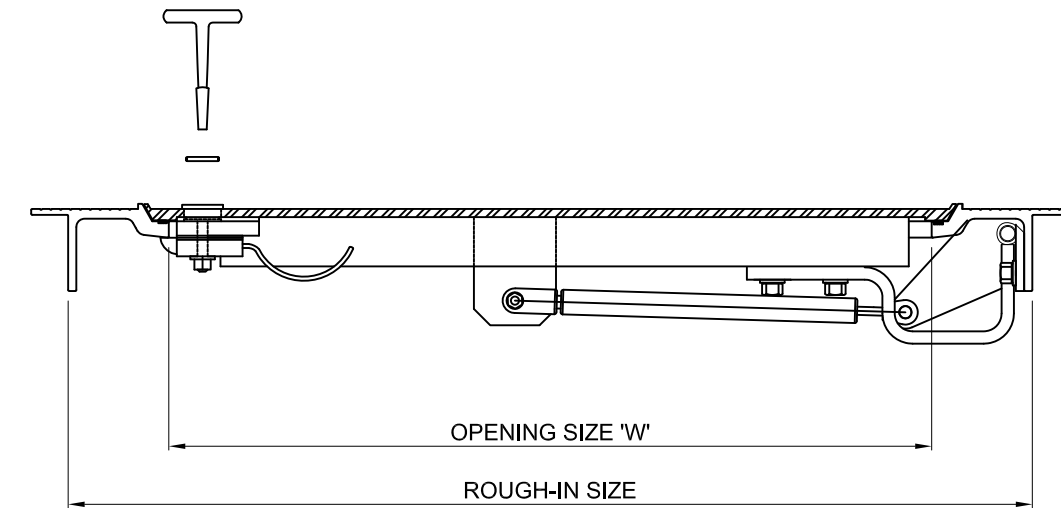

DOOR IN CLOSED POSITION

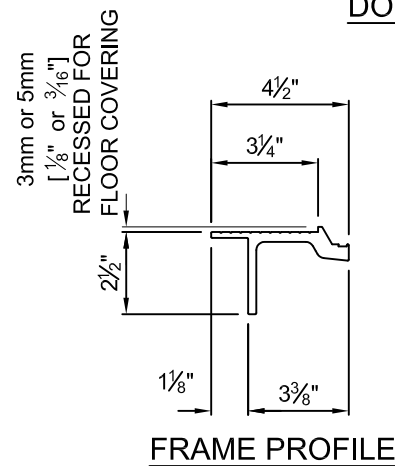

FRAME PROFILE

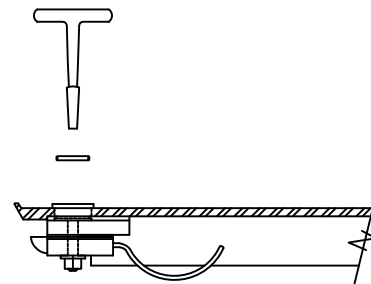

SPRING LATCH ASSEMBLY DETAIL

REMOVE REMOVABLE PLUG AND INSERT ' T ' HANDLE TO OPEN.

**Model MT - Aluminum Floor Door, Single Leaf  
Non-Rated Floor Door**

INSTALLATION INTO:

- |   |  |
|---|--|
| <input type="checkbox"/> - CAST-IN-PLACE CONCRETE.  | <input type="checkbox"/> - WOOD FRAMING. |
| - UNDERSIDE OF FRAME TO RECEIVE BITUMINUS COATING.  |  |
| - ANCHOR BOLTS ARE SUPPLIED LOOSE AND MUST BE ATTACHED TO THE HOLES PROVIDED IN THE FRAME BEFORE CASTING THE UNIT IN PLACE. |  |

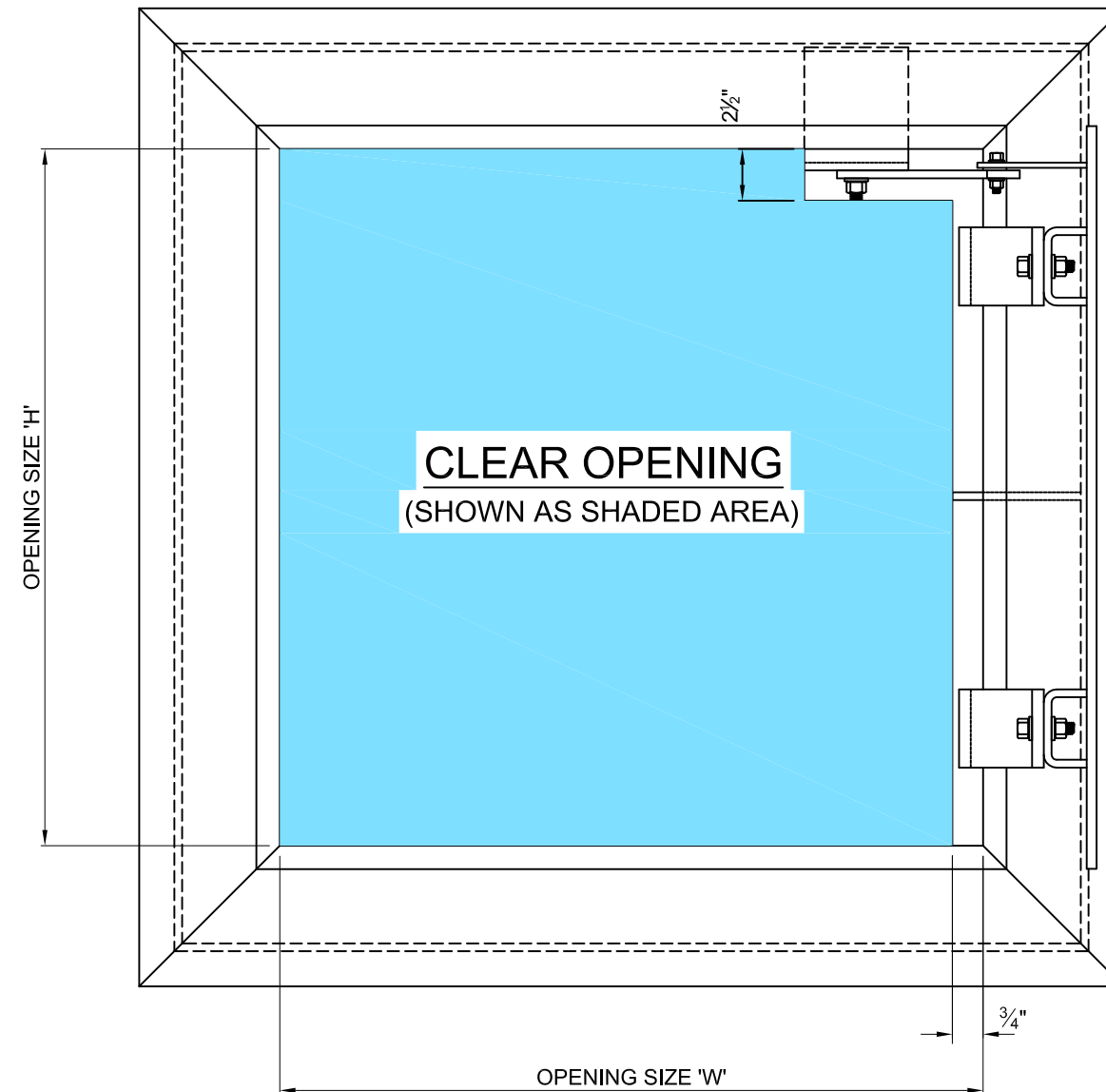
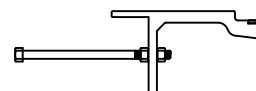

OPTIONS:

- STAINLESS STEEL HARDWARE.

NOTE:  
- READ THIS DRAWING IN CONJUNCTION WITH SHEET 1 OF 2.



#5 7978 North Fraser Way  
Burnaby B.C. V5J 0C7  
Ph. 604-433-4243  
Fax. 604-433-4148

PROJECT :	
CONTRACTOR :	
ARCH. OR ENG. :	
PURCHASE ORDER :	
APPROVED BY :	
DATE :	SHEET 2 OF 2