



Maxam Metal Products Ltd.
British Columbia, Canada

Tel: 604-433-4243
Fax: 604-433-4148

Toll Free Tel: 1-866-446-2926
Toll Free Fax: 1-866-436-2926

Website: www.maxammetal.com
Email: info@maxammetal.com

36" X 30" [914mm X 762mm] ROOF HATCH

FACTORY FINISHES

ALUMINUM - MILL FINISH

HARDWARE - STAINLESS STEEL SPRING LATCH WITH
INTERNAL & EXTERNAL PADLOCK HASPS.

NOTE : - HOLD OPEN ARM - STANDARD POWDER COATED
SAFETY RED.
- NUMBER OF HINGES AND COIL SPRINGS WILL
VARY WITH SIZE OF HATCH.

* Specifications subject to change without notice.

LIMITED 5 YEAR WARRANTY

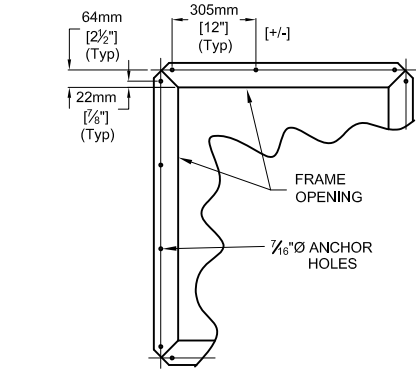

ANCHOR HOLE LAYOUT

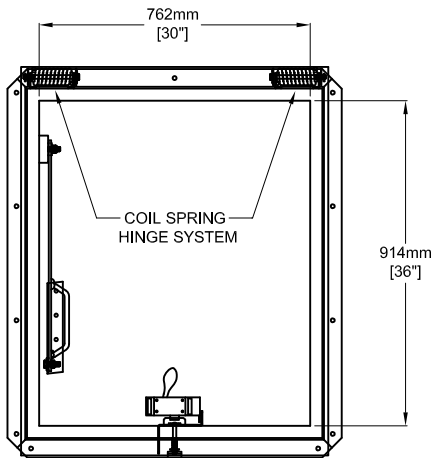

PLAN VIEW

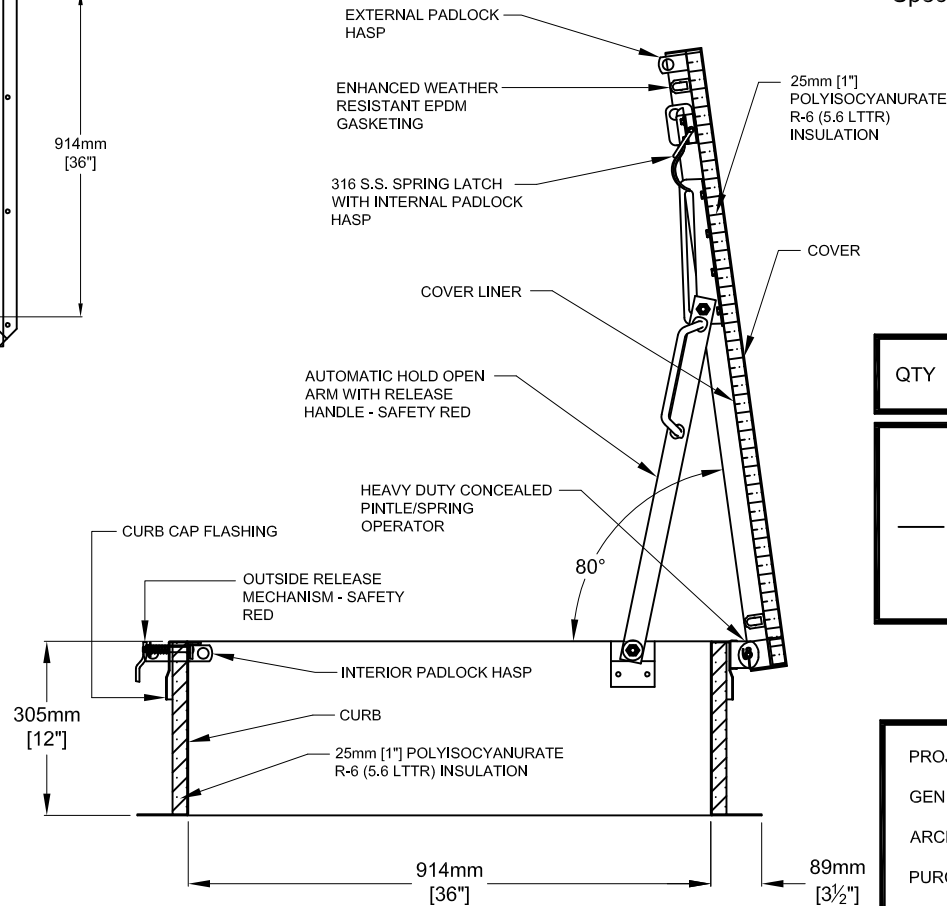
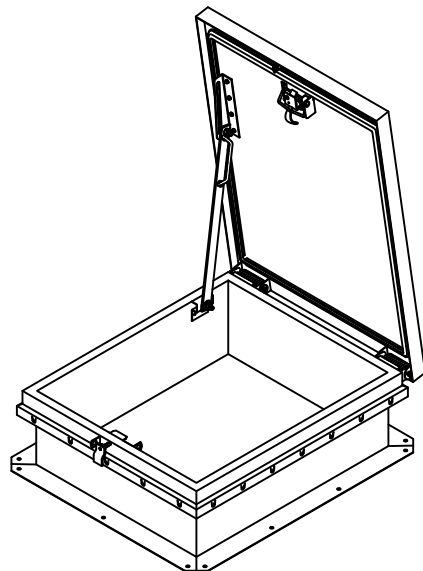

SECTION

QTY	MODEL	MATERIAL	COVER	CURB	COVER LINER
—	RHA-15	ALUM	ALUM 12 ga 2.05mm	ALUM 10 ga 2.60mm	ALUM 12 ga 2.05mm

PROJECT: _____

GEN. CONTRACTOR: _____

ARCH. OR ENG.: _____

PURCHASE ORDER: _____ DATE: _____

APPROVED BY: _____