

Maxam Metal Products Ltd.  
British Columbia, Canada

Tel: 604-433-4243  
Fax: 604-433-4148

Toll Free Tel: 1-866-446-2926  
Toll Free Fax: 1-866-436-2926

Website: www.maxammetal.com  
Email: info@maxammetal.com

## 36" X 36" [914mm X 914mm] ROOF HATCH

### FACTORY FINISHES

ALUMINUM - MILL FINISH

HARDWARE - STAINLESS STEEL SPRING LATCH WITH  
INTERNAL & EXTERNAL PADLOCK HASPS.

NOTE : - HOLD OPEN ARM - STANDARD POWDER COATED  
SAFETY RED.  
- NUMBER OF HINGES AND COIL SPRINGS WILL  
VARY WITH SIZE OF HATCH.

\* Specifications subject to change without notice.

### LIMITED 5 YEAR WARRANTY

QTY	MODEL	MATERIAL	COVER	CURB	COVER LINER
-----	-------	----------	-------	------	-------------

—	RHA-16	ALUM	ALUM 12 ga 2.05mm	ALUM 10 ga 2.60mm	ALUM 12 ga 2.05mm
---	--------	------	-------------------------	-------------------------	-------------------------

PROJECT: \_\_\_\_\_

GEN. CONTRACTOR: \_\_\_\_\_

ARCH. OR ENG.: \_\_\_\_\_

PURCHASE ORDER: \_\_\_\_\_ DATE: \_\_\_\_\_

APPROVED BY: \_\_\_\_\_

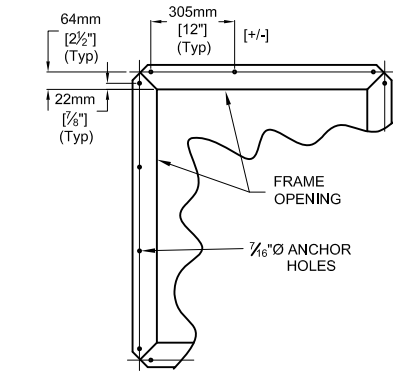

### ANCHOR HOLE LAYOUT

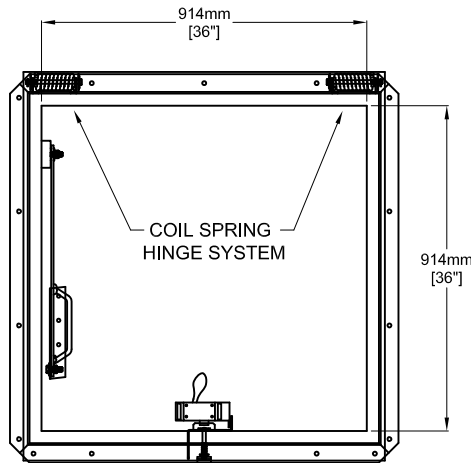

### PLAN VIEW

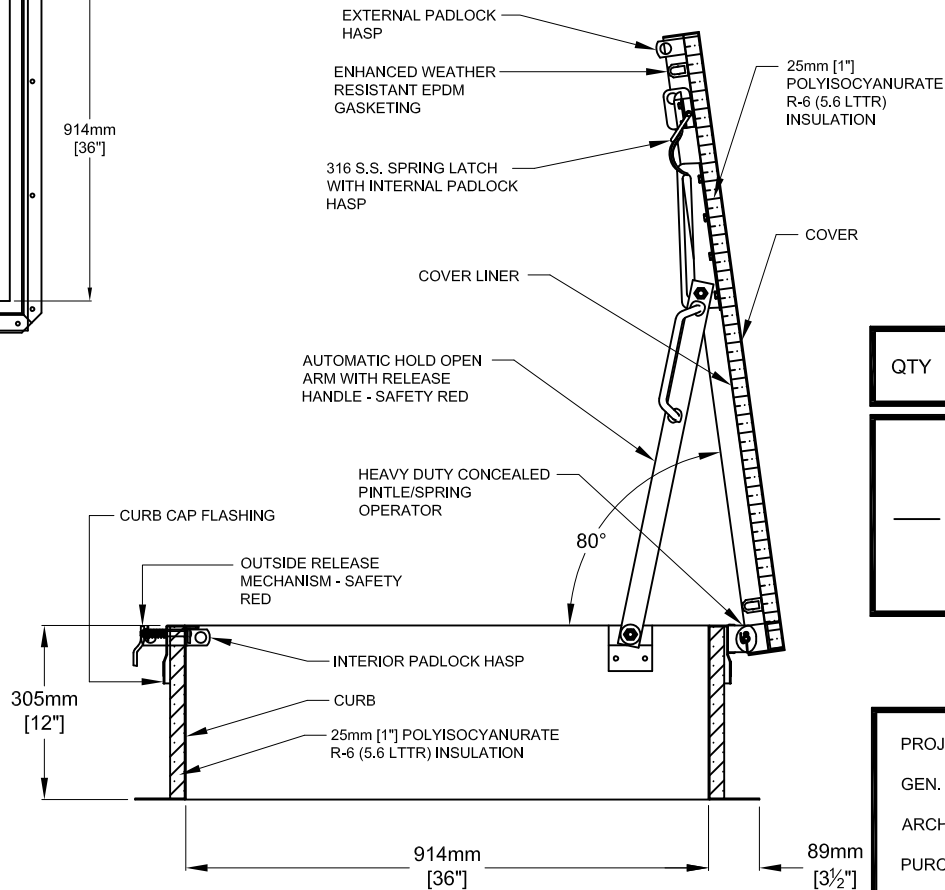
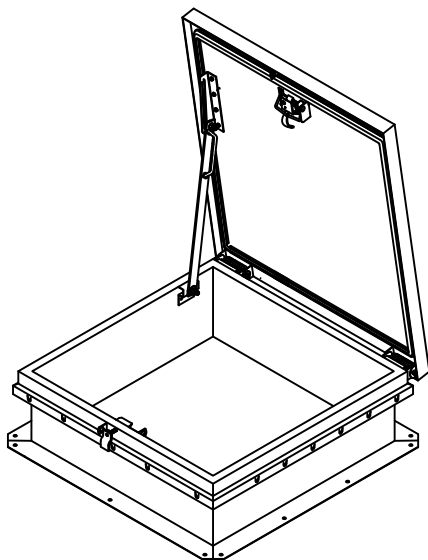

### SECTION