



Maxam Metal Products Ltd.  
British Columbia, Canada

Tel: 604-433-4243  
Fax: 604-433-4148

Toll Free Tel: 1-866-446-2926  
Toll Free Fax: 1-866-436-2926

Website: www.maxammetal.com  
Email: info@maxammetal.com

## 36" X 36" [914mm X 914mm] ROOF HATCH

### FACTORY FINISHES

GALVANIZED (GALVANNEALED) STEEL - GREY PRIME

HARDWARE - ZINC PLATED SPRING LATCH c/w INTERNAL & EXTERNAL PADLOCK HASPS.

NOTE: - HOLD OPEN ARM - STANDARD POWDER COATED SAFETY RED.  
- NUMBER OF HINGES AND COIL SPRINGS WILL VARY WITH SIZE OF HATCH.  
- LIVE LOAD = 40 LBS PER SQUARE FOOT.

\* Specifications subject to change without notice.

### ANCHOR HOLE LAYOUT

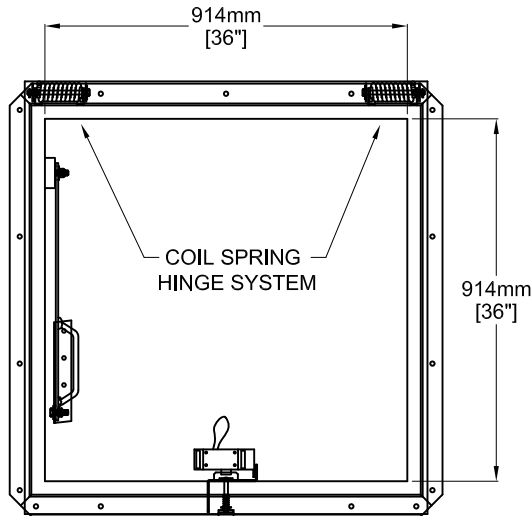
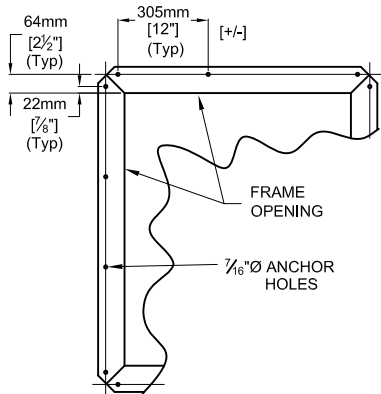

**PLAN VIEW**

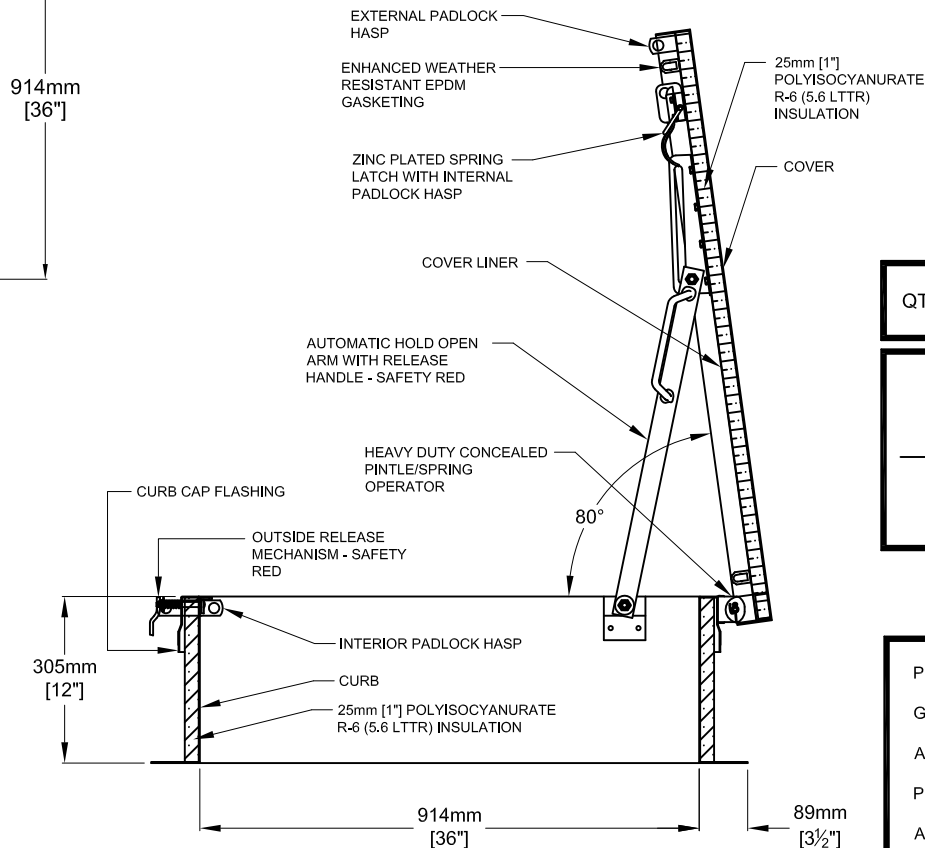
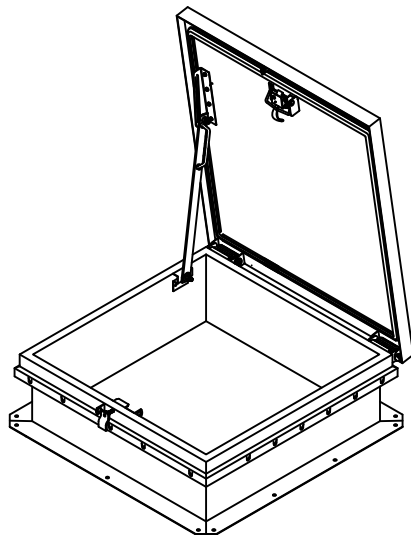

**SECTION**

### LIMITED 5 YEAR WARRANTY

QTY	MODEL	MATERIAL	COVER	CURB	COVER LINER
-----	-------	----------	-------	------	-------------

—	RHS-2	GALV. STEEL	STEEL 14 ga 1.99mm	STEEL 14 ga 1.99mm	STEEL 22 ga 0.85mm
---	-------	-------------	--------------------------	--------------------------	--------------------------

PROJECT: \_\_\_\_\_

GEN. CONTRACTOR: \_\_\_\_\_

ARCH. OR ENG.: \_\_\_\_\_

PURCHASE ORDER: \_\_\_\_\_ DATE: \_\_\_\_\_

APPROVED BY: \_\_\_\_\_