

**ANCHOR
HOLE
LAYOUT**

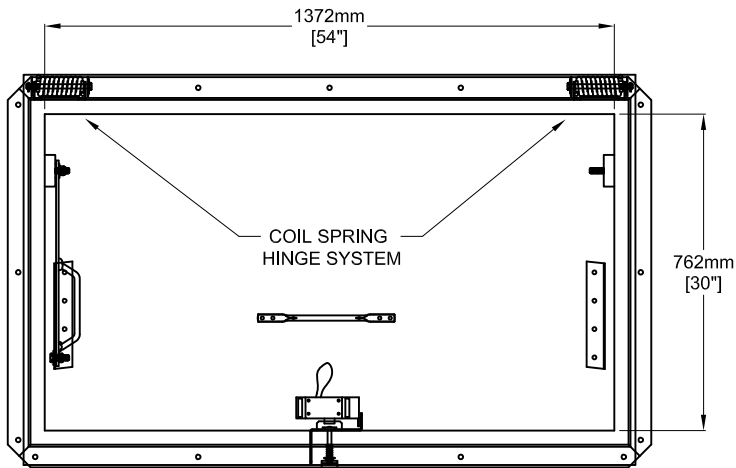

PLAN VIEW

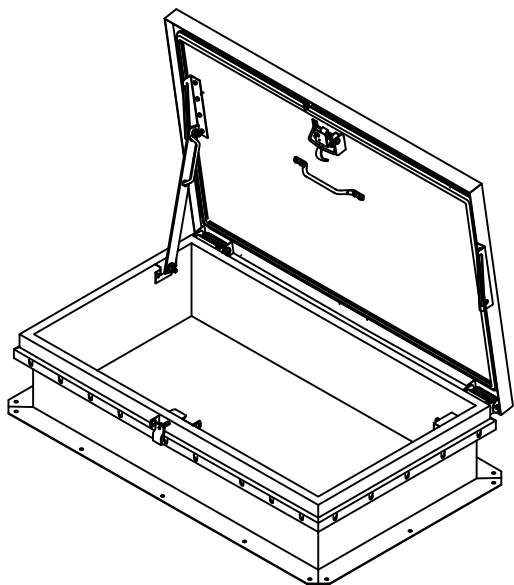

Maxam Metal Products Ltd.
British Columbia, Canada

Tel: 604-433-4243
Fax: 604-433-4148

Toll Free Tel: 1-866-446-2926
Toll Free Fax: 1-866-436-2926

Website: www.maxammetal.com
Email: info@maxammetal.com

**30" X 54" [762mm X 1372mm]
ROOF HATCH**

FACTORY FINISHES

GALVANIZED (GALVANNEALED) STEEL - GREY PRIMER

HARDWARE - ZINC PLATED SPRING LATCH c/w INTERNAL & EXTERNAL PADLOCK HASPS.

- NOTE: - HOLD OPEN ARM - STANDARD POWDER COATED SAFETY RED.
- NUMBER OF HINGES AND COIL SPRINGS WILL VARY WITH SIZE OF HATCH.
- HOLD OPEN ARM DESIGNED TO BE MOVABLE FROM ONE SIDE TO ANOTHER TO ACCOMMODATE SITE CONDITION.
- LIVE LOAD = 40 LBS PER SQUARE FOOT.

* Specifications subject to change without notice.

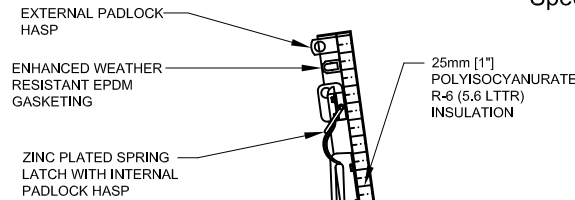

LIMITED 5 YEAR WARRANTY

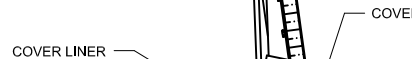

AUTOMATIC HOLD OPEN ARM WITH RELEASE HANDLE - SAFETY RED

HEAVY DUTY CONCEALED PINTLE/SPRING OPERATOR

80°

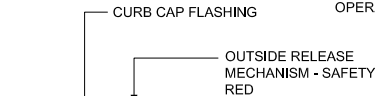

305mm [12"]

762mm [30"]

89mm [3 1/2"]

SECTION

QTY	MODEL	MATERIAL	COVER	CURB	COVER LINER
-----	-------	----------	-------	------	-------------

—	RHS-5	GALV. STEEL	STEEL 14 ga 1.99mm	STEEL 14 ga 1.99mm	STEEL 22 ga 0.85mm
---	-------	-------------	--------------------	--------------------	--------------------

PROJECT: _____

GEN. CONTRACTOR: _____

ARCH. OR ENG.: _____

PURCHASE ORDER: _____ DATE: _____

APPROVED BY: _____