



Maxam Metal Products Ltd.
British Columbia, Canada

Tel: 604-433-4243
Fax: 604-433-4148

Toll Free Tel: 1-866-446-2926
Toll Free Fax: 1-866-436-2926

Website: www.maxammetal.com
Email: info@maxammetal.com

30" X 72" [762mm X 1829mm] ROOF HATCH

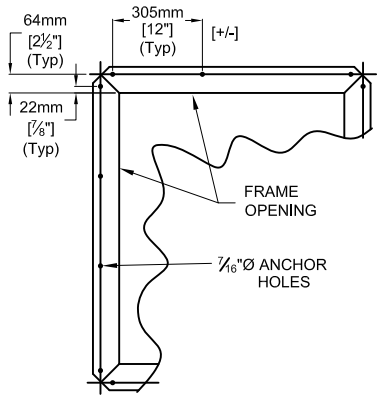

ANCHOR HOLE LAYOUT

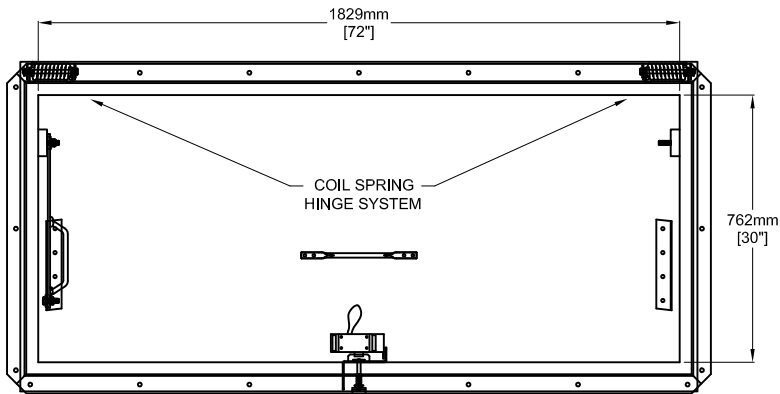

PLAN VIEW

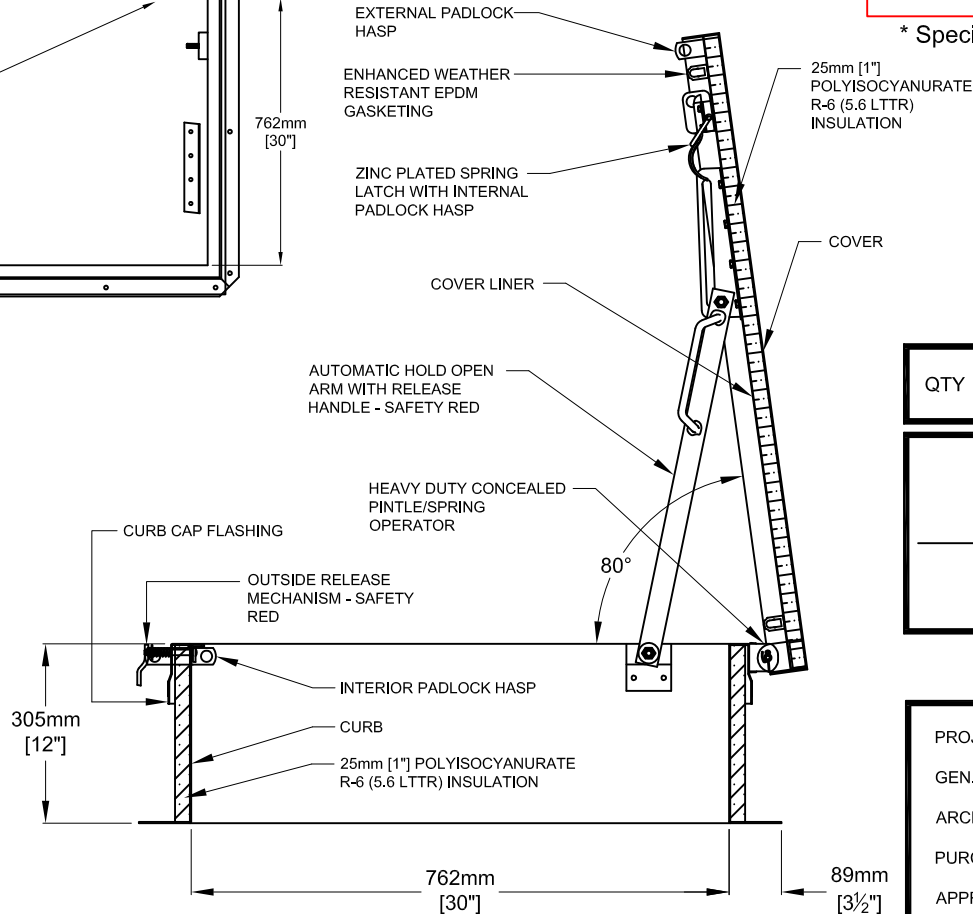
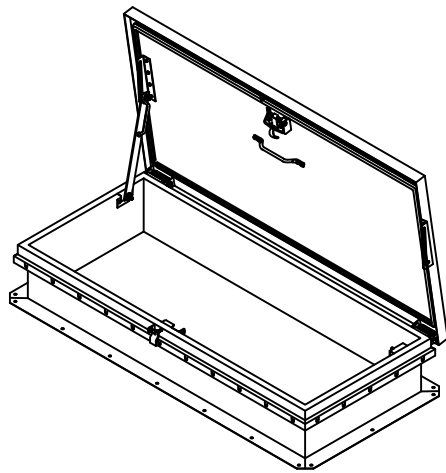

SECTION

FACTORY FINISHES

GALVANIZED (GALVANNEALED) STEEL - GREY PRIMER

HARDWARE - ZINC PLATED SPRING LATCH c/w INTERNAL & EXTERNAL PADLOCK HASPS.

NOTE: - HOLD OPEN ARM - STANDARD POWDER COATED SAFETY RED.
- NUMBER OF HINGES AND COIL SPRINGS WILL VARY WITH SIZE OF HATCH.
- HOLD OPEN ARM DESIGNED TO BE MOVABLE FROM ONE SIDE TO ANOTHER TO ACCOMMODATE SITE CONDITION.

* Specifications subject to change without notice.

LIMITED 5 YEAR WARRANTY

QTY	MODEL	MATERIAL	COVER	CURB	COVER LINER
-----	-------	----------	-------	------	-------------

—	RHS-7	GALV. STEEL	STEEL 14 ga 1.99mm	STEEL 14 ga 1.99mm	STEEL 22 ga 0.85mm
---	-------	-------------	--------------------------	--------------------------	--------------------------

PROJECT:	_____
GEN. CONTRACTOR:	_____
ARCH. OR ENG.:	_____
PURCHASE ORDER:	_____ DATE: _____
APPROVED BY:	_____