

ANCHOR HOLE LAYOUT

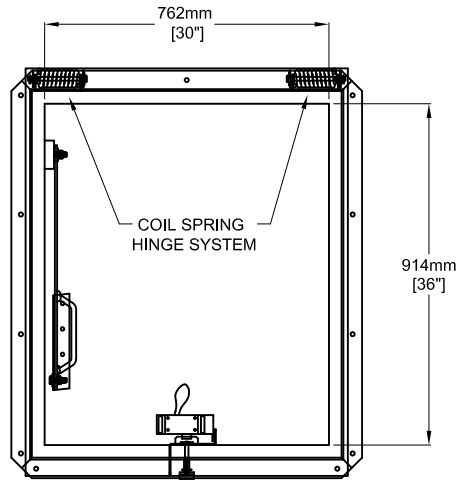

PLAN VIEW

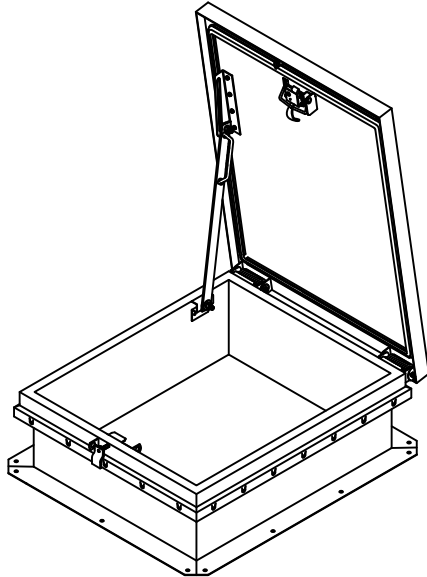

Maxam Metal Products Ltd.
British Columbia, Canada

Tel: 604-433-4243
Fax: 604-433-4148

Toll Free Tel: 1-866-446-2926
Toll Free Fax: 1-866-436-2926

Website: www.maxammetal.com
Email: info@maxammetal.com

36" X 30" [914mm X 762mm] ROOF HATCH

FACTORY FINISHES

GALVANIZED (GALVANNEALED) STEEL - GREY PRIMER

ALUMINUM - MILL FINISH

HARDWARE - STAINLESS STEEL SPRING LATCH c/w
INTERNAL & EXTERNAL PADLOCK HASPS.

NOTE : - HOLD OPEN ARM - STANDARD POWDER COATED
SAFETY RED.
- NUMBER OF HINGES AND COIL SPRINGS WILL
VARY WITH SIZE OF HATCH.

* Specifications subject to change without notice.

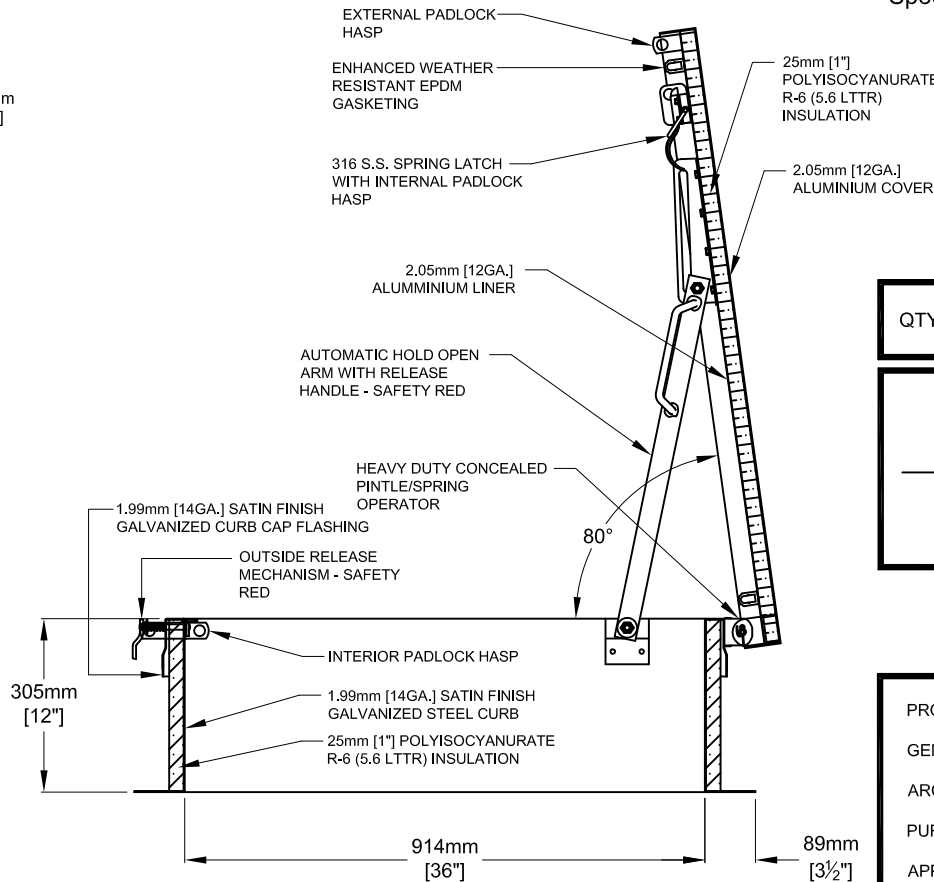

SECTION

LIMITED 5 YEAR WARRANTY

QTY	MODEL	MATERIAL	COVER	CURB	COVER LINER
-----	-------	----------	-------	------	-------------

—	RSA-1	Alum. / Galv. Steel	Alum. 12 ga 2.05mm	Steel 14 ga 1.99mm	Alum. 12 ga 2.05mm
---	-------	---------------------	--------------------	--------------------	--------------------

PROJECT: _____
 GEN. CONTRACTOR: _____
 ARCH. OR ENG.: _____
 PURCHASE ORDER: _____ DATE: _____
 APPROVED BY: _____