



Maxam Metal Products Ltd.
British Columbia, Canada

Tel: 604-433-4243
Fax: 604-433-4148

Toll Free Tel: 1-866-446-2926
Toll Free Fax: 1-866-436-2926

Website: www.maxammetal.com
Email: info@maxammetal.com

30" X 48" [762mm X 1219mm] ROOF HATCH

FACTORY FINISHES

GALVANIZED (GALVANNEALED) STEEL - GREY PRIMER

ALUMINUM - MILL FINISH

HARDWARE - STAINLESS STEEL SPRING LATCH c/w
INTERNAL & EXTERNAL PADLOCK HASPS.

NOTE: - HOLD OPEN ARM - STANDARD POWDER COATED
SAFETY RED.
- NUMBER OF HINGES AND COIL SPRINGS WILL
VARY WITH SIZE OF HATCH.
- HOLD OPEN ARM DESIGNED TO BE MOVABLE
FROM ONE SIDE TO ANOTHER TO
ACCOMMODATE SITE CONDITION.

* Specifications subject to change without notice.

LIMITED 5 YEAR WARRANTY

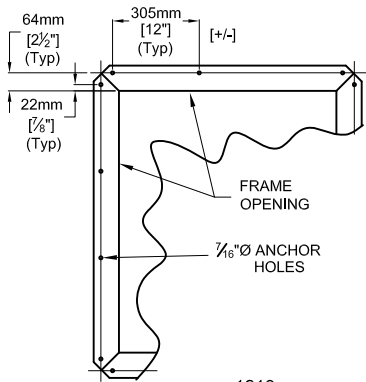

ANCHOR HOLE LAYOUT

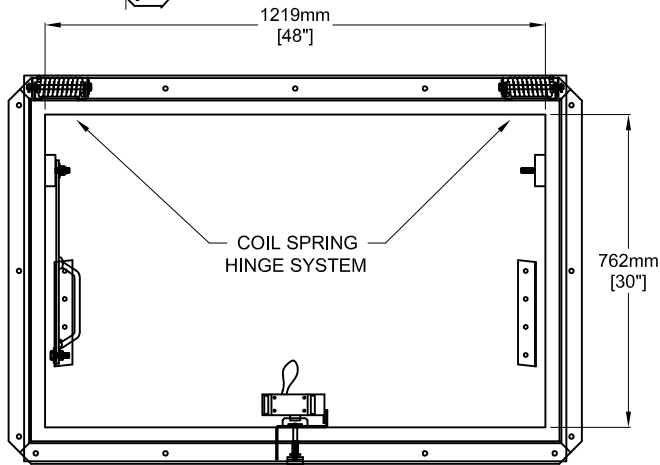

PLAN VIEW

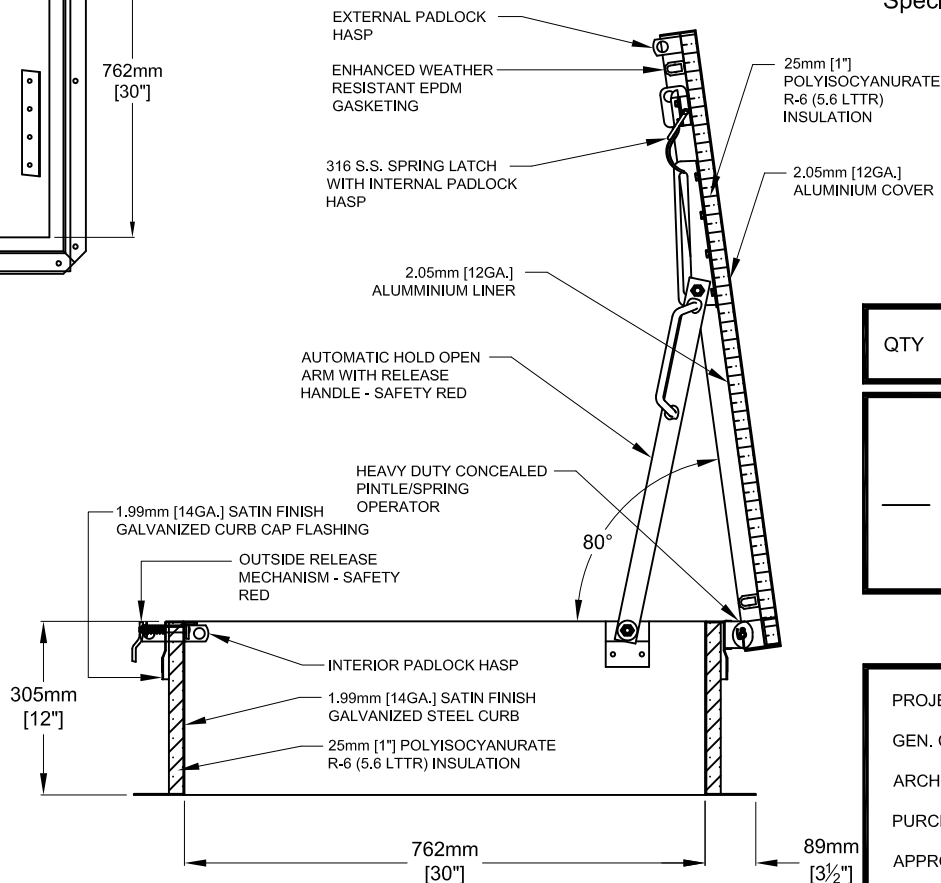
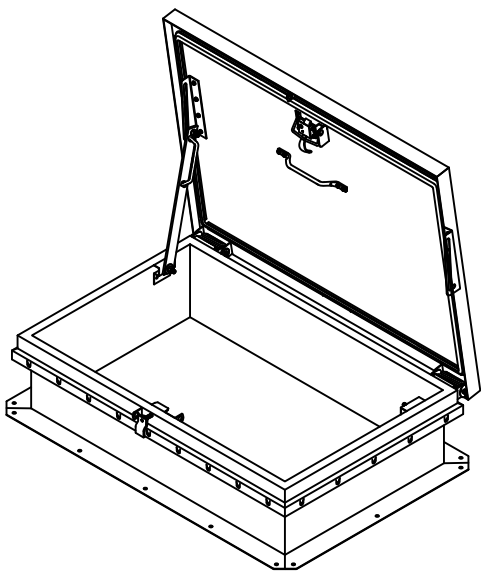

SECTION

QTY	MODEL	MATERIAL	COVER	CURB	COVER LINER
___	RSA-3	Alum. / Galv. Steel	Alum. 12 ga 2.05mm	Steel 14 ga 1.99mm	Alum. 12 ga 2.05mm

PROJECT: _____
 GEN. CONTRACTOR: _____
 ARCH. OR ENG.: _____
 PURCHASE ORDER: _____ DATE: _____
 APPROVED BY: _____