

ACCESS PANELS - CAPW SERIES - Non-Rated with Concealed Touch Latch for Ceilings - CAPW

The Maxam CAPW Series is designed to create a large clear opening for removal or maintaining pumps/equipment. The frame has an exterior wallboard flange and the double doors are formed for rigidity. One operable, one stationary, lightweight and easy to open, close or remove both doors with no visible latches or hinges. This panel is also available in smaller sizes as a single door for stand-alone purchases or to match existing double door CAPW projects.

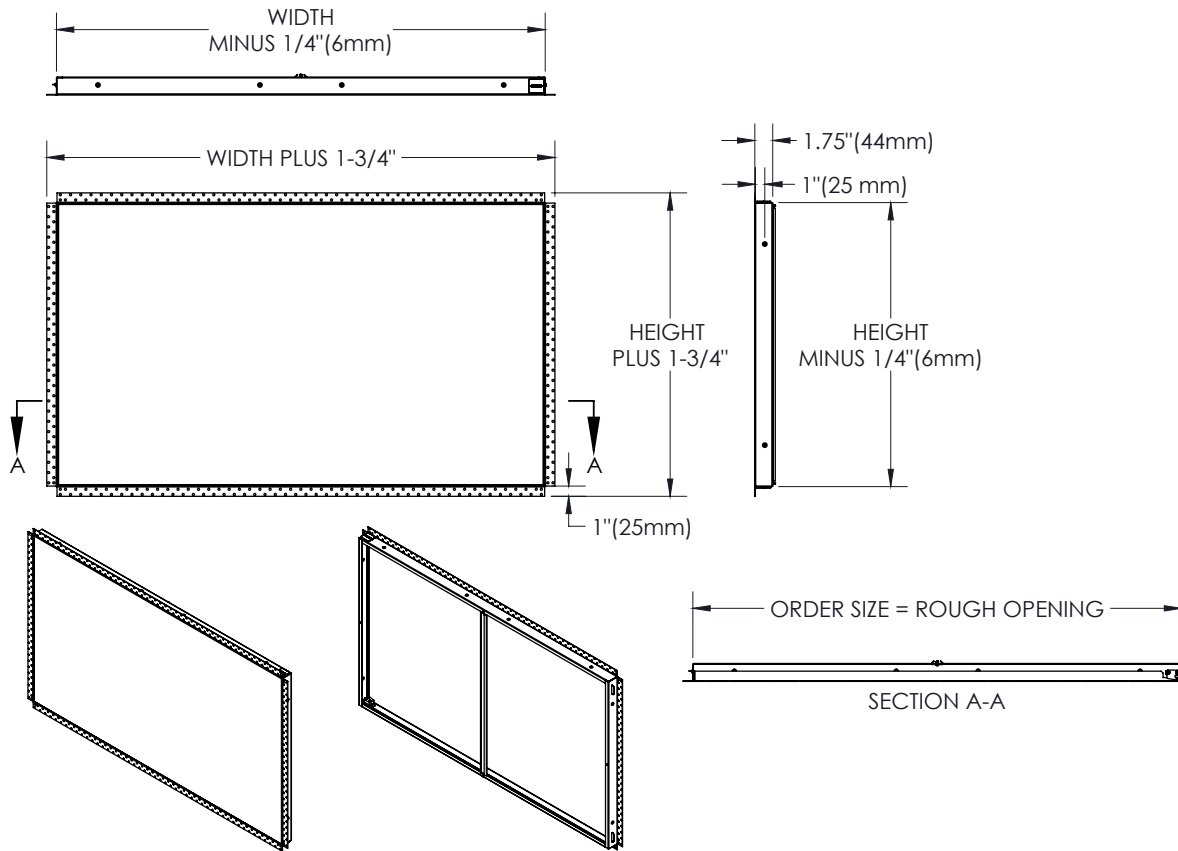

SPECIFICATIONS:

- Frame Material:** 18 gauge galvanized steel
- Door Panel Material:** 20 gauge galvanized steel
- Standard Finish:** Off-white prime coat
- Flange:** 1" (25.4 mm) wallboard flange
- Frame Depth:** 1-3/4" (44.4 mm)
- Safety Chain:** 6" (152 mm) Long safety chains provided on operable door only.
- Latch:** Concealed touch latches on operable door; includes a patent pending latch mounting block.
- Sizes:**
 - Minimum:** 8" x 8" (203 mm x 203 mm)
 - Maximum:** 108" x 54" (2743 mm x 1372 mm)
 - Clear Opening:** (Width minus 1-1/2"/38mm) x (Height minus 1-1/2"/38mm)

ADDITIONAL OPTIONS:

- Optional Material:**
304 stainless steel with #4 finish
- Optional Finishes:**
White powder coat, see color chart on website for other options

NOTE:

ORDER SIZE = ROUGH OPENING

Do not remove center stiffener bar before installation as the frame may warp or bend making installation difficult. After frame is installed the stiffener bar may be removed. Refer to installation instructions before installing the frame and doors.

Interpretation of Building Codes may vary. Consult with the Local Authority Having Jurisdiction (AHJ) to determine appropriate standards.





COMMON SIZES

QTY	MODEL - DOUBLE DOOR	WIDTH X HEIGHT
	CAPWG-4228P-D	42" x 28" (1067mm x 711 mm)
	CAPWG-4236P-D	42" x 36" (1067 mm x 914 mm)
	CAPWG-4848P-D	48" x 48" (1219 mm x 1219 mm)
	CAPWG-6028P-D	60" x 28" (1524 mm x 711 mm)
	CAPWG-7228P-D	72" x 28" (1829 mm x 711 mm)

MADE-TO-ORDER CAPW

QTY	MODEL	MATERIAL	WIDTH	HEIGHT	FINISH	(OPTIONS)
	CAPW (Wallboard Flange)	G (Galvanneal Steel) S (Stainless Steel)	Min: Single door 8" x 8" Double door 16" x 8" Max: 108" x 54"		P (Off-White Primer) W (White Powder Coat) (Other Powder Coat)	D Double Door Min 16" x 8" Single Door Max 54" x 54"

It is the responsibility of the customer to communicate specifications and product performance requirements that are needed for their application. This document is intended to convey potential product configurations and offerings. It is not to be used to imply or represent a specification or rating, of finished products shipped. Detailed, specific submittals can be created upon request. It is the responsibility of the customer to specify product accordingly to comply with local laws, codes, and ordinances.

  MAXAM	 800-554-6077  sales@activarcpg.com  www.activarcpg.com	Distributor:		Project:	
		Contractor:		Approved By:	
		Date:		Architect:	
		Scale: N/A	Page 1 of 1	Item#:	

CANADA ONLY: 604-433-4243 info@maxammetal.com maxammetal.com

THE INFORMATION CONTAINED IN THIS DRAWING IS THE SOLE PROPERTY OF ACTIVAR CONSTRUCTION PRODUCTS GROUP, INC. ANY REPRODUCTION IN PART OR AS A WHOLE WITHOUT WRITTEN PERMISSION IS PROHIBITED.

10-31-2024