



Maxam Metal Products Ltd.
British Columbia, Canada

Tel: 604-433-4243
Fax: 604-433-4148

Toll Free Tel: 1-866-446-2926
Toll Free Fax: 1-866-436-2926

Website: www.maxammetal.com
Email: info@maxammetal.com

24" X 24" [610mm X 610mm] ROOF HATCH

FACTORY FINISHES

GALVANIZED (GALVANNEALED) STEEL - GREY PRIMER
HARDWARE - ZINC PLATED SPRING LATCH c/w INTERNAL & EXTERNAL PADLOCK HASPS.

NOTE: - HOLD OPEN ARM - STANDARD POWDER COATED SAFETY RED.
- NUMBER OF HINGES AND COIL SPRINGS WILL VARY WITH SIZE OF HATCH.
- LIVE LOAD = 40 LBS PER SQUARE FOOT.

* Specifications subject to change without notice.

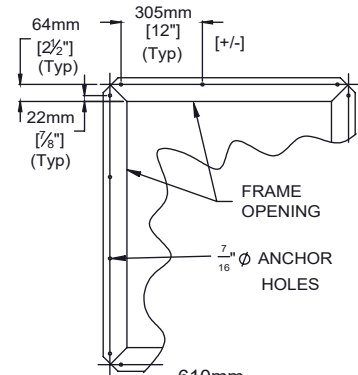

ANCHOR HOLE LAYOUT

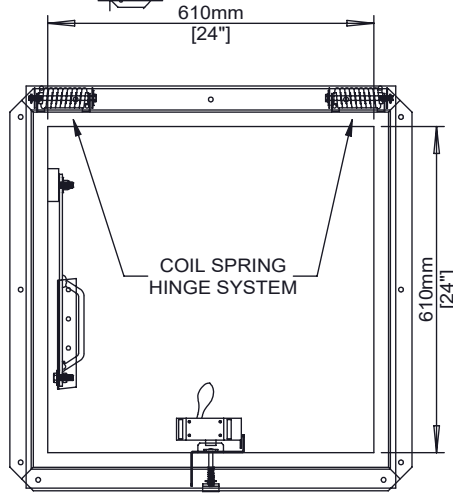

PLAN VIEW

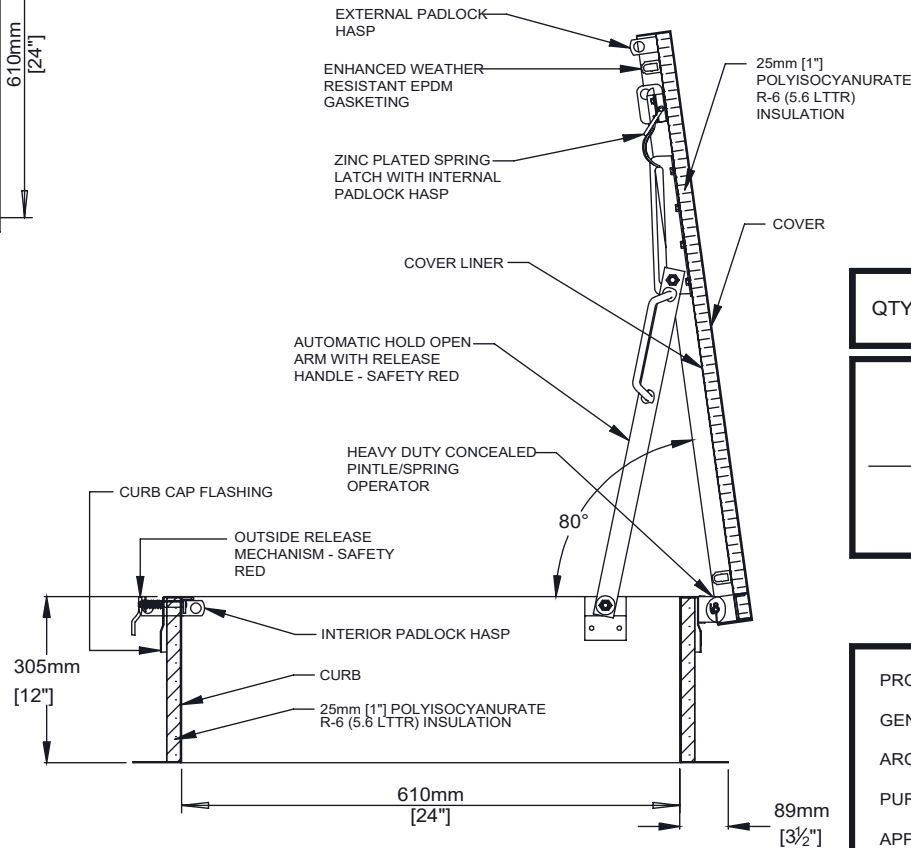
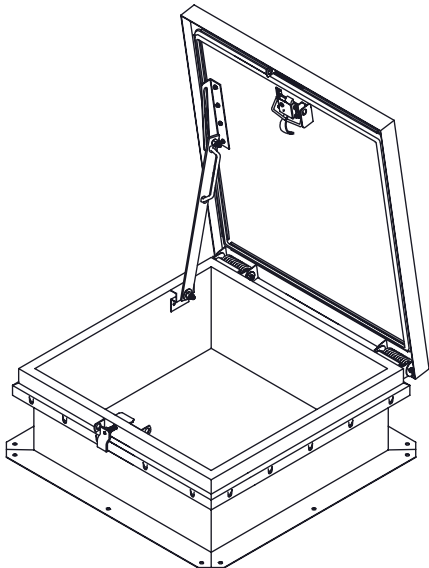

SECTION

LIMITED 5 YEAR WARRANTY

QTY	MODEL	MATERIAL	COVER	CURB	COVER LINER
_____	RHS24X24	GALV. STEEL	STEEL 14 ga 1.99mm	STEEL 14 ga 1.99mm	STEEL 22 ga 0.85mm

PROJECT: _____
 GEN. CONTRACTOR: _____
 ARCH. OR ENG.: _____
 PURCHASE ORDER: _____ DATE: _____
 APPROVED BY: _____