

2 HOUR FIRE-RATED ACCESS PANELS - FWD SERIES: UNINSULATED, DOUBLE DOOR

Our FWD two hour fire-rated uninsulated double door access panels with removable center mullion are durably designed for large size door applications while maintaining the continuity of a fire barrier when installed in vertical walls.

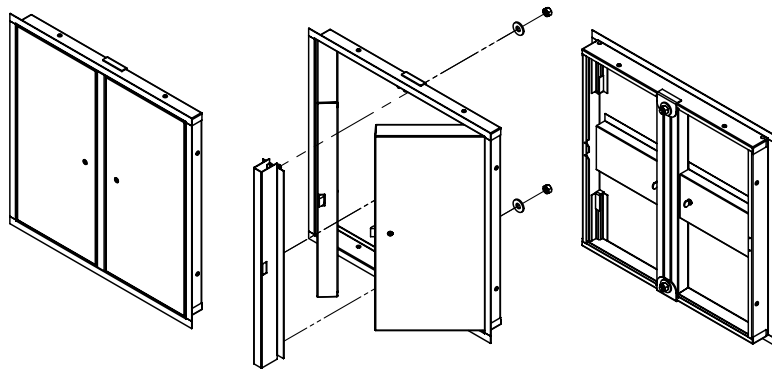
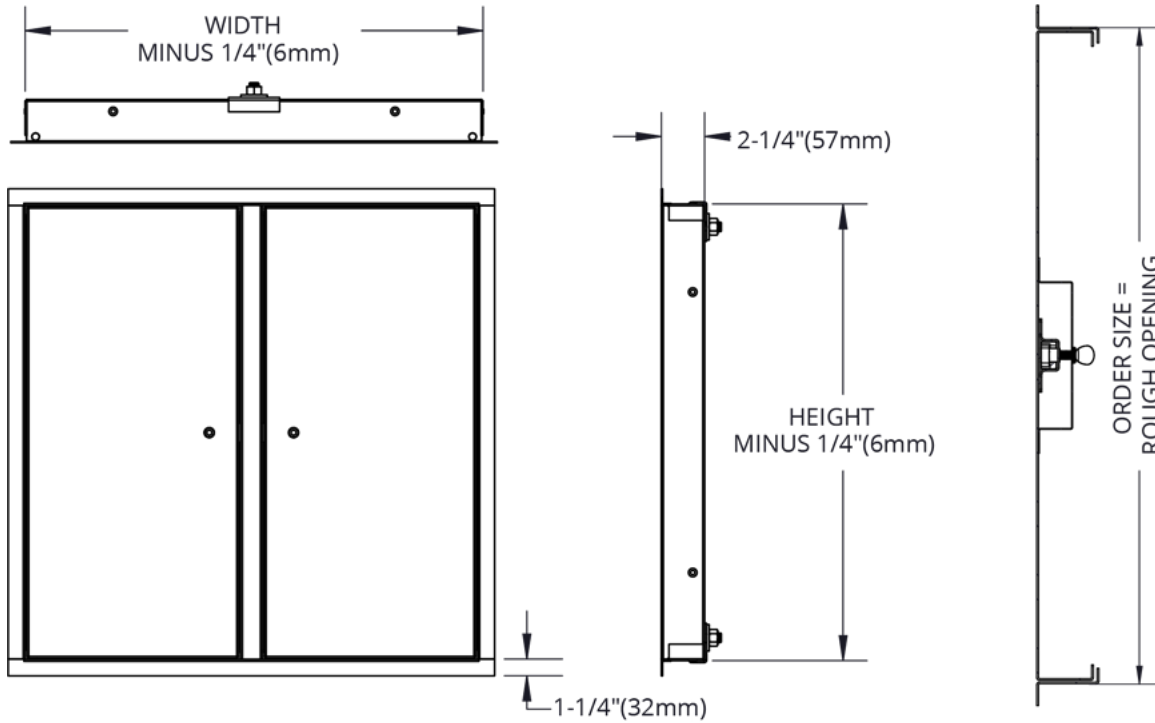

SPECIFICATIONS:

- Frame Material:** 16 gauge (1.61mm) galvalneal steel
- Frame Flange:** 1-3/4" (32mm) with 2" (51 mm) removable center mullion
- Frame Depth:** 2-1/2" (63.5 mm)
- Door Panel Material:** 16 gauge (1.6 mm) galvalneal steel
- Standard Finish:** Off white prime coat
- Hinge:** Concealed 3/8" steel stud rod hinge
- Closer:** Zinc-plated steel tension springs that automatically close when door is open ~90° per NFPA 80
- Latch:** Self-latching, flush 1/4" Allen key with interior release

- Sizes:**
- Minimum:** 36" x 12" (914 x 305 mm)
 - Maximum:** 48" x 80" (1219 mm x 2032 mm) or 73-1/4" x 50-3/8" (1861 mm x 1280 mm)
 - Clear Opening:** Width minus 1-1/2" (38 mm) x Height minus 1-1/2" (38mm) with center mullion removed

FIRE-RATING:
Intertek Warnock Hersey Listed and Labeled: 2 Hour Fire-Rating per NFPA 252, UL 10B, CAN/ULC S104 for vertical installations



- OPTIONS:**
- Optional Latches:** Mortise lock, mortise preparation
 - Additional Options:** Smoke gasket, masonry anchor straps, powder coat finish

NOTE:
ORDER SIZE W x H = ROUGH OPENING

COMMON SIZES

QTY	Order Size		No. of Latches	Approx. Weight	
	W X H (Rough Opening)			kg	lbs
	inches	mm			
	36 x 60	914 x 1524	4	31.30	69
	42 x 42	1067 x 1067	4	26.31	58
	42 x 60	1067 x 1524	4	35.83	79
	48 x 48	1219 x 1219	4	33.11	73
	48 x 60	1219 x 1524	4	39.92	88
	Custom - specify size:				

It is the responsibility of the customer to communicate specifications and product performance requirements that are needed for their application. This document is intended to convey potential product configurations and offerings. It is not to be used to imply or represent a specification or rating, of finished products shipped. Detailed, specific submittals can be created upon request. It is the responsibility of the customer to specify product accordingly to comply with local laws, codes, and ordinances.

		800-554-6077 sales@activarcpg.com www.activarcpg.com	Distributor:		Project:	
			Contractor:		Approved By:	
CANADA ONLY: 604-433-4243 info@maxammetal.com maxammetal.com			Date:		Architect:	
			Scale: N/A	Page 1 of 1	Item#:	